

NELSON™ HEAT TRACING SYSTEMS

Z1-PLT-BS-M25/-75NPT SPLICE CONNECTION KIT

INSTALLATION INSTRUCTIONS

DESCRIPTION

The Z1-PLT-BS Splice Connection Kit is designed for splicing two heater cables in an in-line configuration. This kit is designed for use with all wattages of Nelson Heat Tracing Systems' LT-J, LT-JT and HLT-J heater cables. The Z1-PLT-BS-M25 provides compatibility to M25 metric thread standard and the Z1-PLT-BS-75NPT provides compatibility to 0.75" NPT thread standard.

KIT CONTENTS

- | | |
|-------------------------|---|
| 1 Enclosure | 1 Sealing Grommet |
| 2 Power Terminal Blocks | 2 Power End Termination, 101.6mm (4.0") |
| 1 Ground Terminal Block | 2 G/Y Tubing, 9.5mm (0.38") diameter, 152mm (6") length |
| 1 Stand-off | 1 Tube of Silicone |
| 1 Box Adapter | |
| 1 Locknut | |

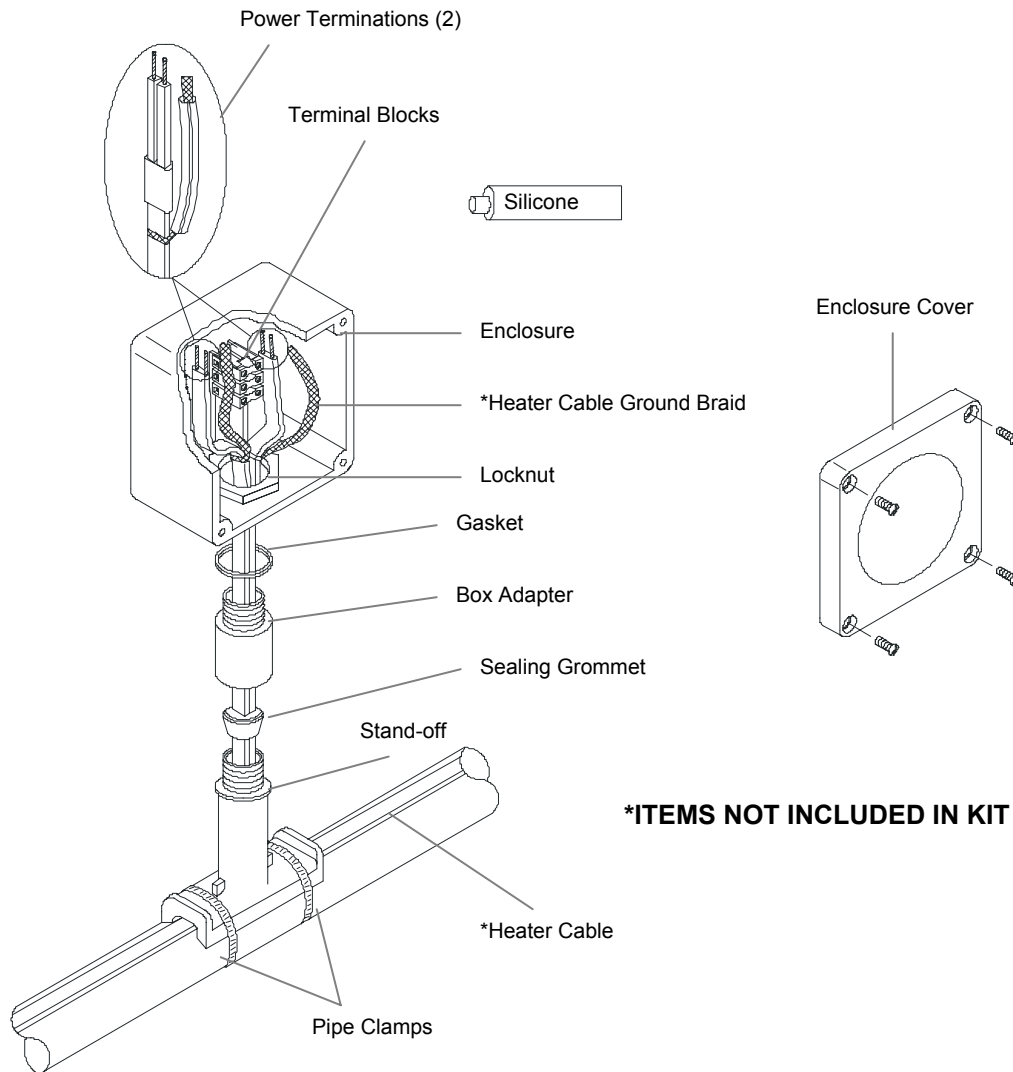

⚠ WARNING:

If nuisance tripping of ground fault breakers occurs due to condensation in the enclosure, electrical connections should be moisture proofed by use of a coating or sealant.

NELSON™ HEAT TRACING SYSTEMS

Z1-PLT-BS-M25/-75NPT SPLICE CONNECTION KIT

INSTALLATION INSTRUCTIONS

STAND-OFF POSITIONING

Section View A A

(recommend installing at the
4 or 8 o'clock positions)

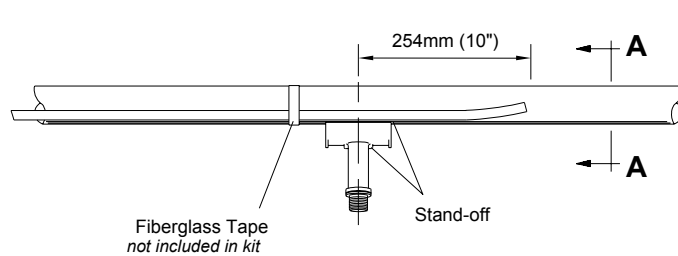
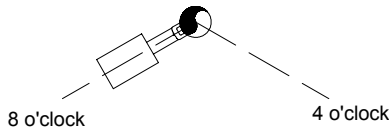

WARNING:

Do not place pipe clamps
over heater cable.

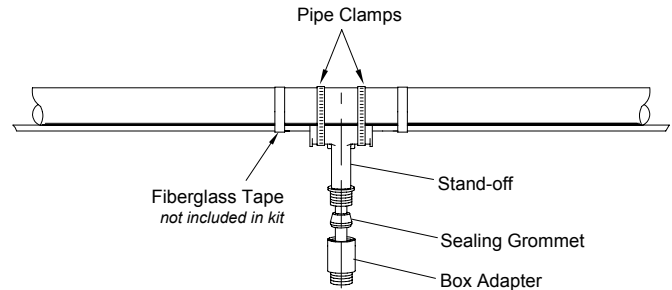

- 1) Mark pipe where stand-off will be mounted. See diagram above.
- 2) Push both heater cables through the bottom opening of stand-off.
- 3) Place stand-off on the pipe and fasten with pipe clamps.
- 4) Slide the sealing grommet over both heater cables and position inside stand-off opening.
- 5) Apply silicone around the heater cables on top of the sealing grommet and fill any voids in sealing grommet.
- 6) Slide the box adapter over both heater cables and tighten securely to stand-off.
- 7) Apply silicone around the locknut and threads of the box adapter to secure the assembly.
- 8) Prepare both heater cables for power termination. Proceed to sheet 3.

NELSON™ HEAT TRACING SYSTEMS

Z1-PLT-BS-M25/-75NPT SPLICE CONNECTION KIT

INSTALLATION INSTRUCTIONS

HEATING CABLE PREPARATION FOR NELSON LT-J, LT-JT & HLT-J PRODUCTS

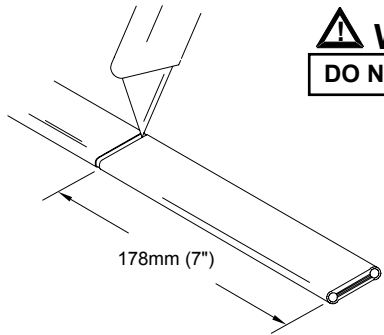

⚠ WARNING:
DO NOT CUT BRAID

- 1) Lightly cut around heater overjacket 178mm (7") from the end. Bend cable to break the overjacket.
- 2) Lightly cut overjacket up the center between first cut mark and the cable end. Bend cable to break overjacket.

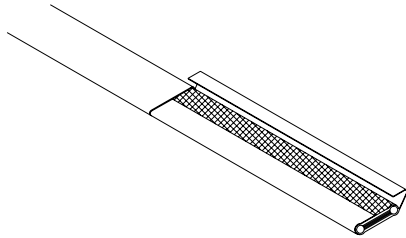

- 3) Remove overjacket from heater cable.

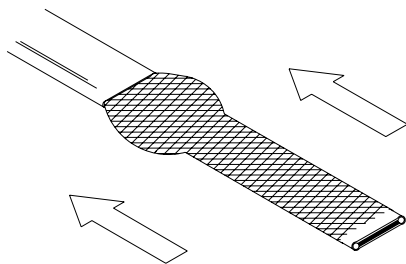

- 4) Move braid back toward the overjacket, creating a bulge.

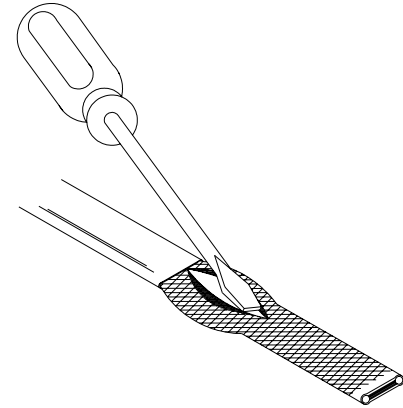

- 5) At the bulge, separate the braid to make an opening.

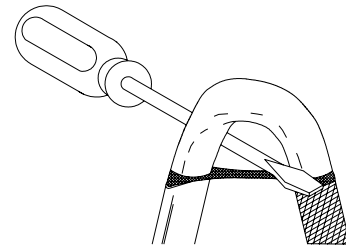

- 6) While bending the heater cable, work it through the braid opening.

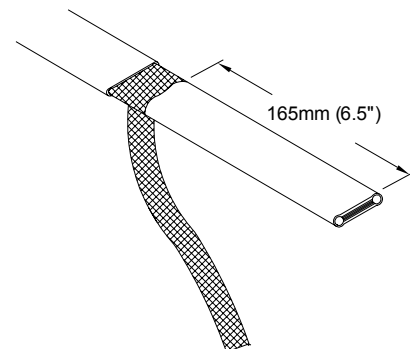

- 7) Pull the braid tight.
- 8) Proceed to sheet 4.

NELSON™ HEAT TRACING SYSTEMS

Z1-PLT-BS-M25/-75NPT SPLICE CONNECTION KIT

INSTALLATION INSTRUCTIONS

HEATING CABLE PREPARATION FOR NELSON LT-J, LT-JT & HLT-J PRODUCTS

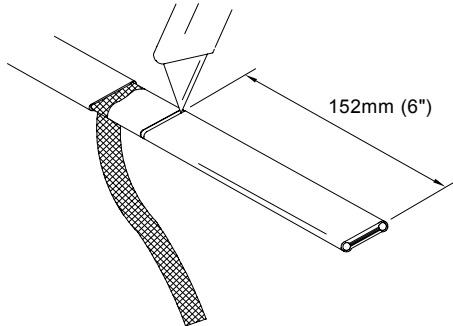

- 1) Lightly cut around cable outer jacket 152mm (6") from the end. Bend cable to break outer jacket.
- 2) Lightly cut the outer jacket up the center between the first cut mark & the cable end. Bend cable to break outer jacket.

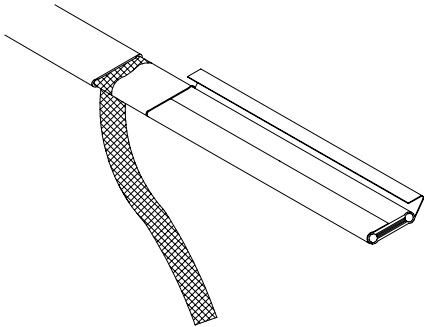

- 3) Remove the jacket from the heater cable.

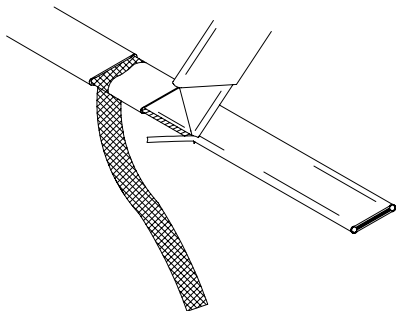

- 4) Shave the core material from the outside of each bus wire.

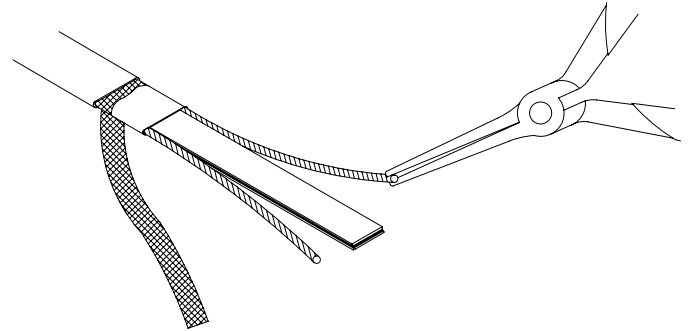

- 5) Starting at the end, pull each bus wire away from the core material.
- 6) Remove exposed core material.

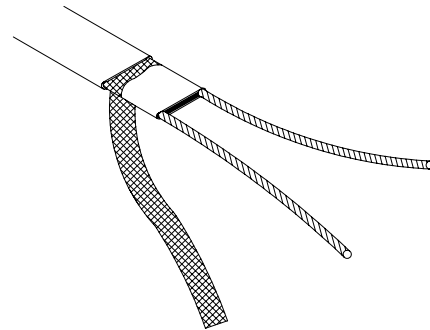

- 7) Cut 6mm (0.25") off the end of each bus wire.
- 8) Proceed to sheet 5.

⚠ WARNING:
DO NOT CUT BUS WIRES

NELSON™ HEAT TRACING SYSTEMS

Z1-PLT-BS-M25/-75NPT SPLICE CONNECTION KIT

INSTALLATION INSTRUCTIONS

POWER TERMINATION FOR NELSON LT-J, LT-JT & HLT-J PRODUCTS

WARNINGS

- Bus wires must not touch or cross while inserting into power termination.
- Only power terminations / end seals specifically approved for the vendors' style and type of heater cable must be used.

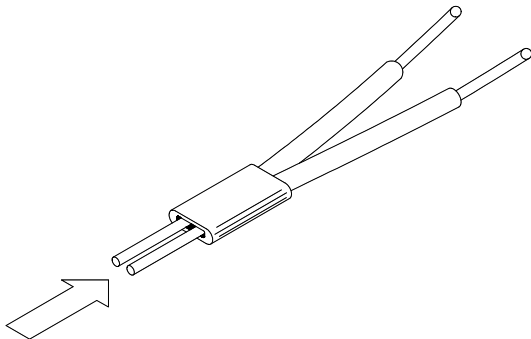

- 1) Insert bus wires into power termination.

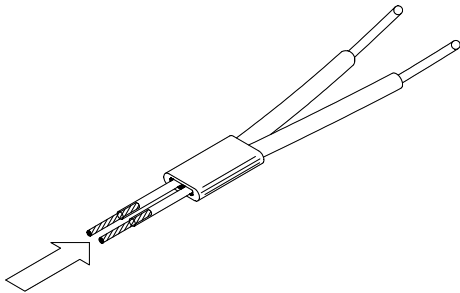

- 2) Insert bus wires into guide tubes.

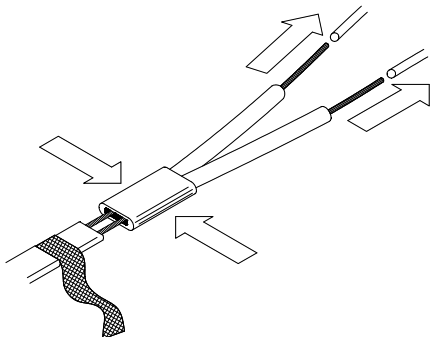

- 3) Remove guide tubes.
4) Squeeze power termination opening and fill with silicone.

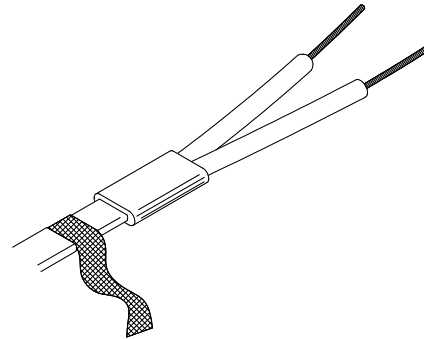

- 5) Push power termination to overlap jacket.
6) The silicone will set up in about 30 minutes with a complete cure after 24 hours.

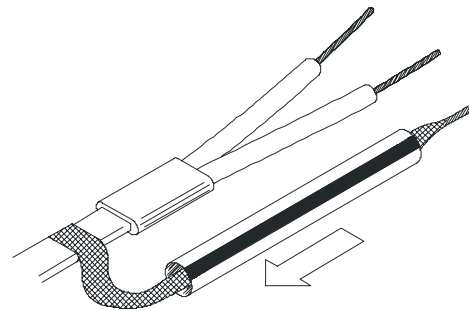

- 7) Slide green/yellow tubing over ground braid before terminating heater to supplied terminals.

WARNING:

- Do not megger or hi-pot until silicone is completely cured.
- Braid must be kept away from bus wires or shorting will occur.

NELSON™ HEAT TRACING SYSTEMS

Z1-PLT-BS-M25/-75NPT SPLICE CONNECTION KIT

INSTALLATION
INSTRUCTIONS

POWER CONNECTION FOR NELSON LT-J, LT-JT & HLT-J PRODUCTS

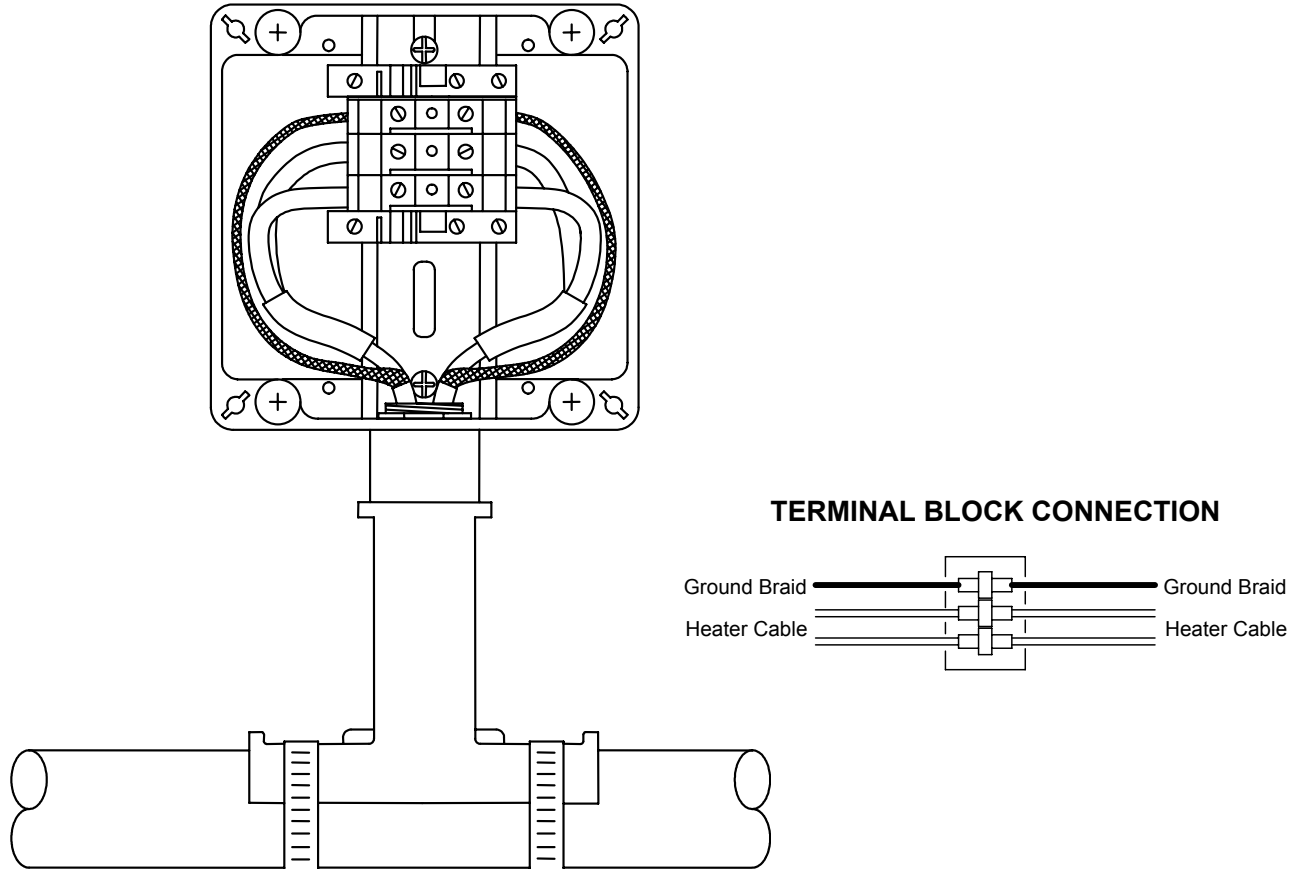

- 1) Place gasket on box adapter.
- 2) Position enclosure on box adapter and apply silicone around the locknut before securing.
- 3) Connect bus wires and ground braid from both heater cables to the terminal block. See diagram above.
- 4) Push all wires and terminal block inside the enclosure.
- 5) Place the cover onto the enclosure.

Nelson Heat Tracing Systems products are supplied with a limited warranty. Complete Terms and Conditions may be found on Nelson's website at www.nelsonheaters.com.